

DIMENSIONED FLOOR PLAN  
1/4"=1'-0"

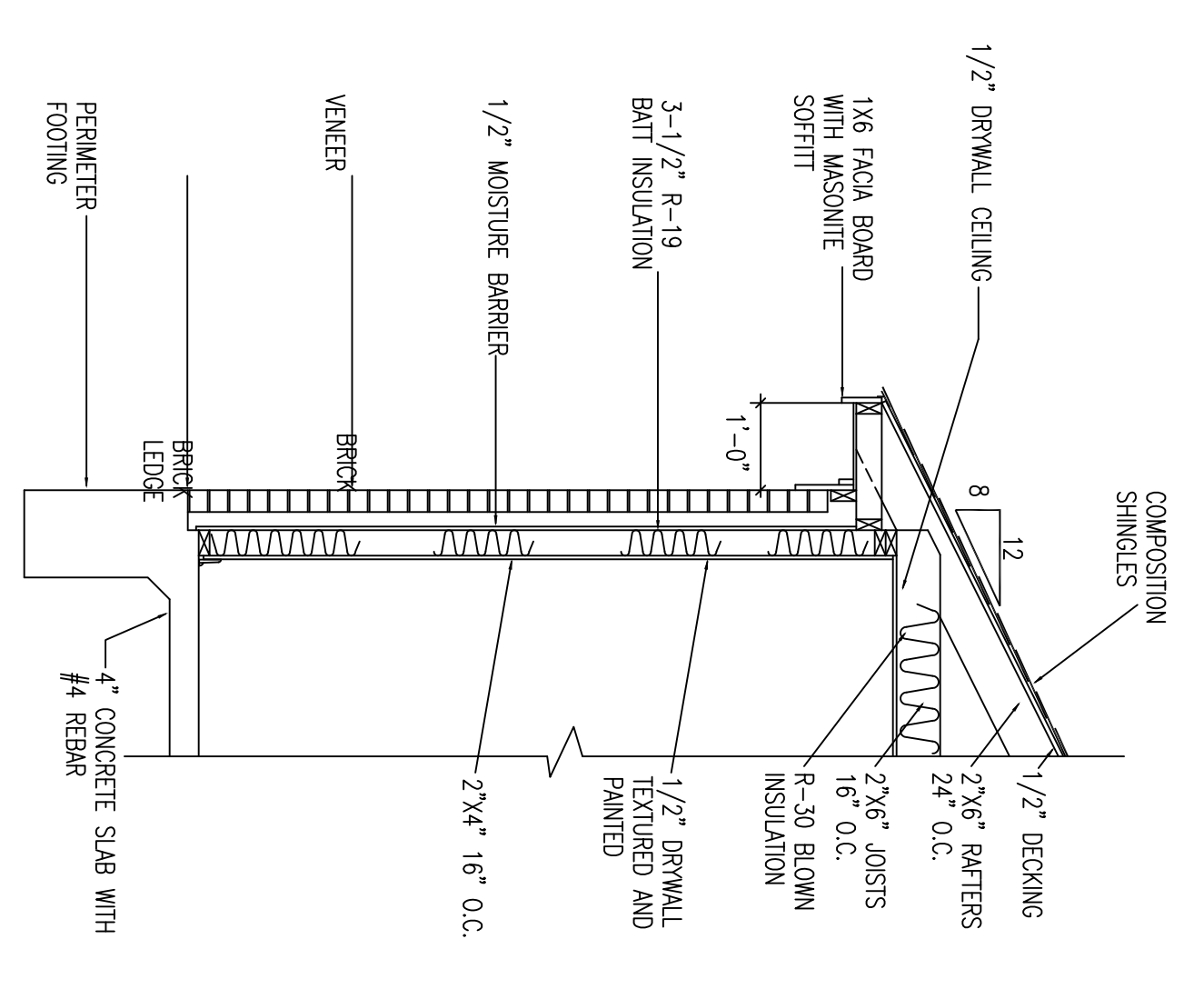

AREA PLAN  
1/16"=1'-0"

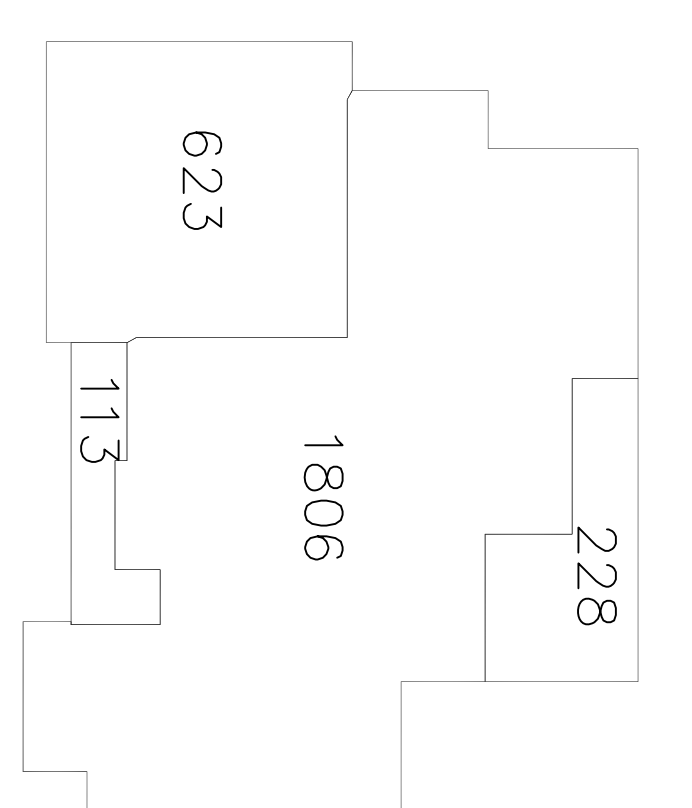

GENERAL NOTES:  
1. MAIN ROOF SLOPE IS 8/12 SLOPE.  
PORCH ROOF SLOPE IS 4/12 SLOPE.

2. PLANS ARE NOT BASED ON ACTUAL SITE CONDITIONS. CONTRACTOR TO VERIFY SLAB AND FILL DIRT ADJUSTMENTS BASED ON SLOPE CONDITIONS.
3. FOUNDATION TO BE SLAB ON GRADE.
4. ALL OVERHANGS AT ROOF SOFFIT ARE 1'-0".
5. SHINGLES TO BE 30 YEAR COMPOSITION SHINGLES.
6. ALL WINDOWS AND DOOR WINDOWS TO BE DOUBLE PANE, LOW-E GLASS.

DOOR SCHEDULE

A	3'-0"x6'-8" ENTRY DOOR WITH ARCHED TRANSOM
B	2'-8"x6'-8" RANGED PANEL INTERIOR DOOR
C	2'-4"x6'-8" RANGED PANEL INTERIOR DOOR
D	2'-2'-0"x6'-8" RANGED PANEL INTERIOR POCKET DOOR
E	3'-0"x6'-8" RANGED PANEL EXTERIOR DOOR
F	3'-0"x6'-8" FULL LITE EXTERIOR DOOR
G	18'-0"x7'-0" SECTIONAL GARAGE DOOR
H	2'-4"x6'-8" RANGED PANEL INTERIOR POCKET DOOR
J	2'-8"x6'-8" RANGED PANEL INTERIOR POCKET DOOR
K	3'-0"x6'-8" RANGED PANEL INTERIOR DOOR
L	2'-3'-0"x6'-8" FULL LITE EXTERIOR DOORS

WINDOW SCHEDULE

1	TWIN 3'-0"x6'-0" DOUBLE INSULATED, DIVIDED LITE WITH EXTERIOR
2	TWIN 3'-0"x6'-6" DOUBLE INSULATED, DIVIDED LITE WITH EXTERIOR
3	2'-0"x5'-0" DOUBLE INSULATED, DIVIDED LITE WITH RAISED TOP
4	3'-8"x11'-0" DOUBLE INSULATED, FULL LITE
5	TWIN 3'-0"x6'-0" DOUBLE INSULATED, FULL LITE
6	3'-0"x5'-0" DOUBLE INSULATED, FULL LITE
7	TWIN 3'-0"x6'-0" DOUBLE INSULATED, FULL LITE
8	TRIPLE 2'-6"x6'-0" DOUBLE INSULATED, FULL LITE
9	4'-0"x11'-0" DOUBLE INSULATED, FULL LITE
10	3'-0"x6'-6" DOUBLE INSULATED, FULL LITE WITH ARCHED TOP

REVISED  
1806-LEFT FRONT  
2J HOME BUILDERS, LLC  
TYLER, TEXAS  
OCTOBER 8, 2020